

Bidirectional HV – 48V – 12V DC/DC Converter

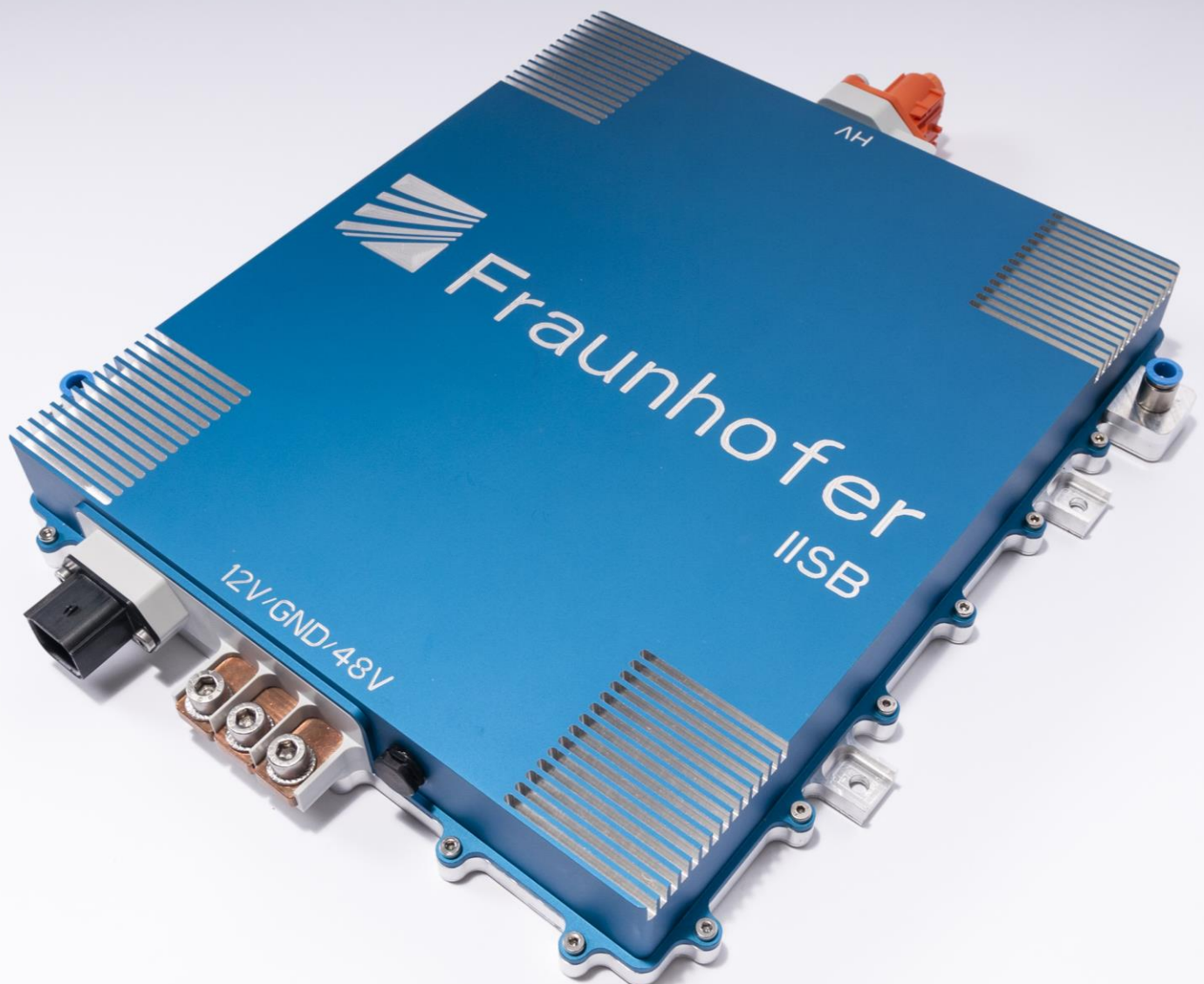

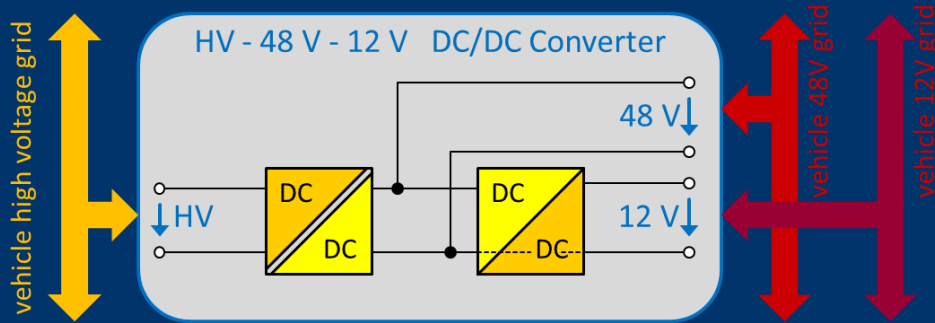

Bidirectional HV – 48V – 12V DC/DC Converter

Description

The presented HV - 48V - 12V DC/DC converter is a typical example for a customer oriented power electronics development project together with the Fraunhofer IISB. The realized on-board DC/DC converter has three independent bidirectional ports to connect all future available on-board grids: HV, 48V and 12V. With the converter, complex automotive on-board energy management tasks can be fulfilled, like boosting energy between the 48V and 12V grid, size reduction of the 12V battery, replacement by supercaps or transferring energy between the high voltage grid and the low voltage grids. For safety reasons the 12V as well as the 48V port are galvanically isolated from the HV port. The converter can be fully controlled via CAN. From the numerous features listed in the table on the right, especially the ultra low profile with only 49 mm should be highlighted. Due to the well chosen circuit topology and the advanced design and packaging a very high power density is achieved for a converter with the described high functionality.

Technical Data

HV voltage range	225 V – 430 V
HV current range	± 44 A peak ± 36 A continuous
HV power range	± 10 kW peak ± 8 kW continuous
48 V voltage range	32 V – 52 V
48 V current range	± 200 A peak ± 160 A continuous
48 V power range	± 10 kW peak ± 8 kW continuous
12 V voltage range	9 V – 16 V
12 V current range	± 250 A peak ± 200 A continuous
12 V power range	± 3 kW peak ± 2.4 kW continuous
Dimension	346 mm x 296 mm x 49 mm
Volume	5.0 dm ³
Power Density (@ 13 kW)	2.6 kW/dm ³

Features

- Three independent, bidirectional ports (HV, 48V, 12V)
- all three ports useable at the same time
- galvanic isolation between HV and 48V
- galvanic isolation between HV and 12V
- wide input/output voltage ranges
- over voltage / current protection / temperature control
- voltage & current control modes for all ports
- high partial load efficiency through phase shedding
- CAN communication
- water cooling
- high power density
- ultra low profile
- without electrolytic capacitors
- usable for different electric energy storages (Lilo-batteries, lead acid batteries, supercaps)
- designed for complex automotive on-board energy management tasks

Fraunhofer Institute for Integrated Systems and Device Technology IISB

Schottkystrasse 10
91058 Erlangen, Germany

Contact

Dr. Stefan Zeltner
Tel.: +49 9131 761-140
stefan.zeltner@iisb.fraunhofer.de

www.iisb.fraunhofer.de

Ultra low profile bidirectional DC/DC converter: HV – 48V – 12V

